

INSTRUCTION MANUAL
for
**ACTIVE
MONOPOLE ANTENNA**
(with Remote Interface Option)

Model: **AM-741R**



Table of Contents

1.0 Introduction	4
2.0 Products Available from Com-Power	5
3.0 Product Information	6
3.1 Incoming Inspection	6
3.2 Package Inventory	6
3.3 Product Safety Information	7
3.3.1 Product Hazard Symbols Definitions.....	7
3.3.2 Product Warning/Caution Statements.....	7
3.3.3 General Safety Instructions.....	7
3.4 Product Connections/Controls/Indicators	8
3.5 Product Specifications	11
4.0 Measurement Correction Factors	13
4.1 Antenna Factors.....	14
4.2 Preamplifier Gain Factors	14
4.3 Insertion Loss Factors.....	14
4.3.1 Insertion Loss Measurement.....	15
4.3.1.1 Insertion Loss Measurement Procedure.....	15
5.0 Using your AM-741R Monopole Antenna	16
5.1 Field Strength Measurement Calculations.....	16
5.2 Antenna Positioning.....	18
5.3 Using RAI-100 Remote Antenna Interface Unit	20
6.0 Calibration and Re-Calibration	21
6.1 Calibration of Monopole Antenna	21
6.1.1 Normalization Measurements (V_{NORM})	21
6.1.2 Calibration Measurements (V_{CAL}).....	22
6.1.3 Calibration Calculations	22
7.0 Warranty.....	23
8.0 Typical Active Antenna Factors	24

List of Figures

FIGURE 1 -	AM-741R Connections/Controls/Indicators - Front Panel	8
FIGURE 2 -	AM-741R Connections/Controls/Indicators – Rear Panel	9
FIGURE 3 -	AM-741R Connections/Controls/Indicators - Bottom Panel	9
FIGURE 4 -	RAI-100 Connections/Controls Indicators	10
FIGURE 5 -	AM-741R Active Monopole Antenna Dimensions	12
FIGURE 6 -	RAI-100 Remote Antenna Interface Dimensions	12
FIGURE 7 -	Setup for Reference Measurements (R)	15
FIGURE 8 -	Setup for Insertion Loss Measurements (I)	15
FIGURE 9 -	Typical measurement system for AM-741R	16
FIGURE 10 -	Test Arrangement for MIL-STD 461 (recent editions)	18
FIGURE 11 -	“Classic” Test Arrangement	19
FIGURE 12 -	Fiber Optic Connection from AM-741R to RAI-100	20
FIGURE 13 -	Monopole Calibration Normalization using ECSM Method	21
FIGURE 14 -	Monopole Calibration Measurement using ECSM Method	22

1.0 Introduction

This manual includes descriptions of the AM-741R Active Monopole Antenna connections, controls and indicators; product specifications, safety precautions, operational instructions, calibration instructions, measurement guidelines and warranty information.

Information contained in this manual is the property of Com-Power Corporation. It is issued with the understanding that the material may not be reproduced or copied without the express written permission of Com-Power.

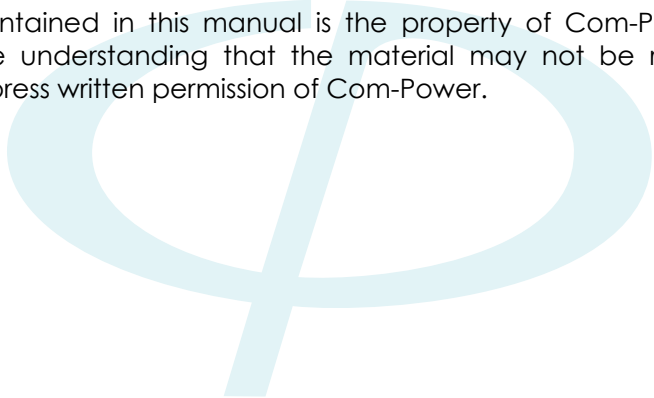

2.0 Products Available from Com-Power



Antennas



Antenna Kits



Absorbing Clamps



*Coupling/Decoupling
Networks (CDN)*



Comb Generators



Current Probes



*Emissions Test
Systems*



*Conducted Immunity
Test Systems*

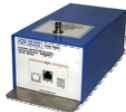

*Impedance Stabilization
Networks (ISN)*



*Line Impedance Stabilization
Networks (LISN)*



Antenna Masts



*Near-Field
Probe Sets*



Preamplifiers



Power Amplifiers

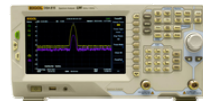

Spectrum Analyzers



*Product Safety Test
Equipment*



Transient Limiters



Turntables



Antenna Tripods



*Telecom Test
Systems*

www.com-power.com

3.0 Product Information

3.1 Incoming Inspection

WARNING – To avoid possibility of electrical shock, do not apply power to the Com-Power AM-741R Active Monopole Antenna if there is any evidence of shipping damage. If shipping damage to the product or any of its accessories is suspected, or if the package contents are not complete, contact Com-Power or your Com-Power distributor.

Please check the contents of the shipment against the package inventory in section 3.2 to ensure that you have received all applicable items.

3.2 Package Inventory

STANDARD ITEMS:

- ✓ **AM-741R Active Monopole Antenna**
- ✓ **6 VDC (unregulated), 500 mA Battery Charger / AC Power Adapter**
- ✓ **Calibration Certificate and Associated Data**

OPTIONAL ITEMS:

- ✓ **RAI-100 Remote Antenna Interface**
- ✓ **Fiber Optic Cable**
- ✓ **6 VDC (unregulated), 500 mA, AC Power Adapter for RAI-100**
- ✓ **AMS-741 Grounding Kit**
- ✓ **AMC-10pF Calibration Capacitor**

3.3 Product Safety Information

3.3.1 Product Hazard Symbols Definitions

The hazard symbols appearing on the product exterior are defined below.



The yellow triangle with an exclamation mark indicates the presence of important operating and/or maintenance (servicing) instructions in the literature accompanying the product.

3.3.2 Product Warning/Caution Statements

CAUTION: Use only the charger supplied by Com-Power. Other chargers may damage the battery.

3.3.3 General Safety Instructions

The following safety instructions have been included in compliance with safety standard regulations. Please read them carefully.

- **READ AND RETAIN INSTRUCTIONS** - Read all safety and operating instructions before operating the instrument. Retain all instructions for future reference.
- **HEED WARNINGS** - Adhere to all warnings on the instrument and operating instructions.
- **FOLLOW INSTRUCTIONS** - Follow all operating and use instructions.
- **WATER AND MOISTURE** - Do not use the instrument near water.
- **WALL OR CEILING MOUNTING** - Do not mount the instrument on a wall or ceiling.
- **HEAT** - The instrument should be situated away from heat sources such as heat registers or other instruments which produce heat.
- **POWER SOURCES** - Connect the instrument only to the type of power source described in the operating instructions or as marked on the instrument.
- **POWER CORD PROTECTION** - Place power supply cords so that they are not likely to be walked on or pinched by items placed on them or against them.
- **CLEANING** - Clean the instrument only as recommended by the manufacturer.
- **DEFECTS AND ABNORMAL STRESS** - Whenever it is likely that the normal operation has been impaired, make the equipment inoperable and secure it against further operation.
- **DAMAGE REQUIRING SERVICE** - Instrument should be serviced by qualified personnel when:
 - ✓ The power supply cord or the plug has been damaged.
 - ✓ Objects have fallen or liquid has been spilled into the instrument.
 - ✓ The instrument has been exposed to rain.
 - ✓ The instrument does not appear to operate normally.
 - ✓ The instrument has been dropped, or the enclosure has been damaged.
- **SITTING OR CLIMBING** - Do not sit or climb upon the instrument or use it as a step or ladder.

3.4 Product Connections/Controls/Indicators

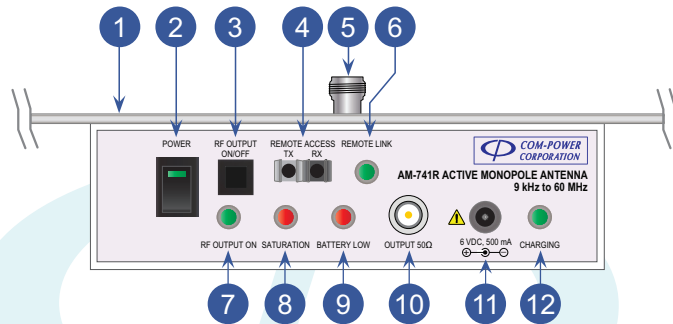

FIGURE 1 - AM-741R Connections/Controls/Indicators - Front Panel

- 1 Counterpoise**
Metallic ground plane affixed to top surface of amplifier housing
- 2 Main Power Switch and LED Indicator**
Activate all Monopole antenna interface/control circuits.
(antenna is in standby mode until RF output is enabled via RF Output ON/OFF toggle switch -- see item 3)
- 3 RF Output ON/OFF Toggle Switch**
Turns on/off Monopole antenna amplifier circuit
- 4 Remote Access Port**
Fiber optic port for connection to RAI-100 Remote Antenna Interface
- 5 Monopole Element Connector**
Type N-female connector for connection of telescoping monopole element, or 10 pF capacitor during calibration
- 6 Remote Link LED Indicator**
Indicates active connection with RAI-100 Remote Antenna Interface
- 7 RF Output On LED Indicator**
Indicates that RF amplifier circuit is active
- 8 Saturation LED Indicator**
Indicates that the amplifier is in saturation
- 9 Battery Low Indicator**
Indicates that the battery level is getting low, and will soon require charging
- 10 Antenna Output Port**
50 ohm, Type N-female coaxial port for connection to measuring instrument
- 11 Power Input Port**
Power input port for connection of provided battery charger / AC adapter
- 12 Battery Charging Indicator**
Indicates that the internal battery pack is being charged

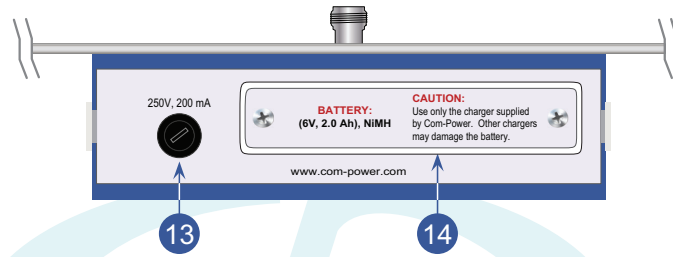

FIGURE 2 - AM-741R Connections/Controls/Indicators – Rear Panel

- 13 Fuse Mounting Assembly**
Provides access to input power fuse
- 14 Battery Access Panel**
Provides access to internal battery pack

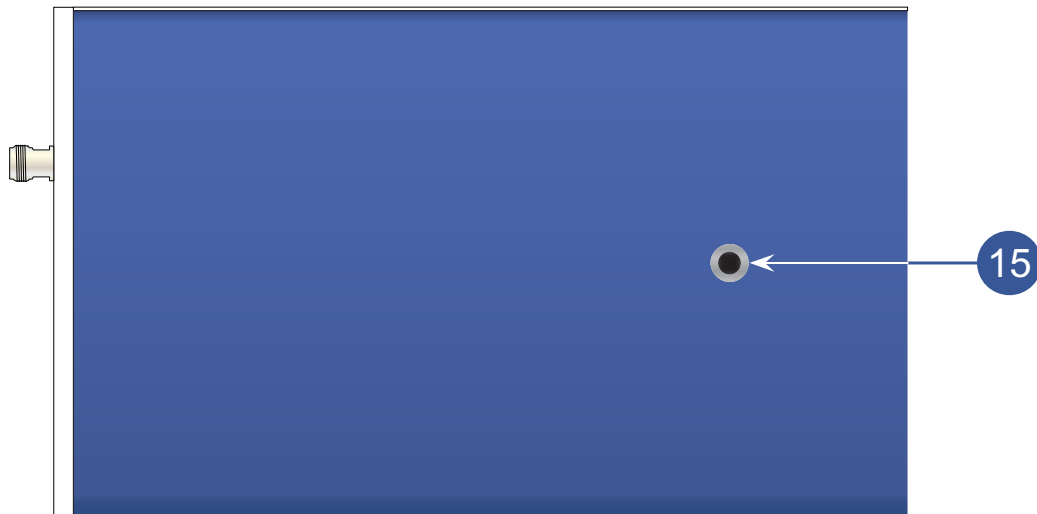

FIGURE 3 - AM-741R Connections/Controls/Indicators - Bottom Panel

- 15 Antenna Mounting Hole ($\frac{1}{4}$ " x 20 threads per inch)**
For mounting Monopole antenna to tripod or other mounting structure

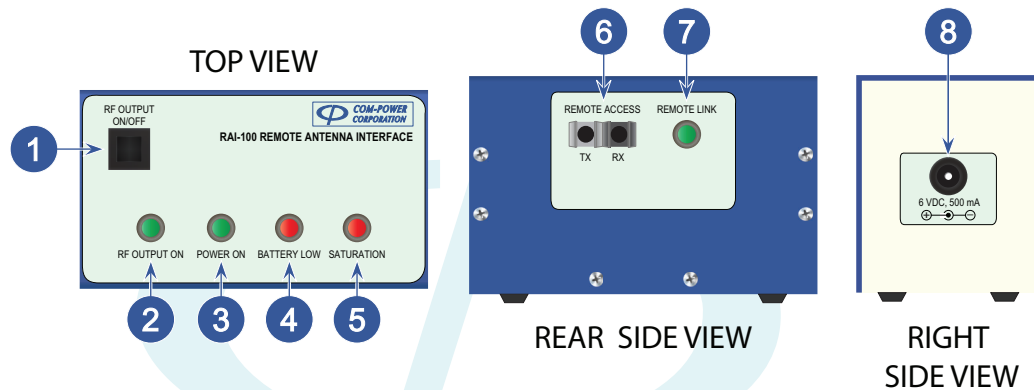

FIGURE 4 - RAI-100 Connections/Controls Indicators

- 1 RF Output ON/OFF Toggle Switch**
Turns on/off Monopole antenna amplifier circuit
- 2 RF Output On LED Indicator**
Indicates that monopole RF amplifier circuit is active
- 3 Power On LED indicator**
Indicates that the AM-741R interface/control circuitry is powered (stand-by mode)
- 4 Battery Low Indicator**
Indicates that the AM-741R battery level is getting low, and will soon require charging
- 5 Saturation LED Indicator**
Indicates that the AM-741R amplifier is in saturation
- 6 Remote Access Port**
Fiber optic port for connection to AM-741R Monopole Antenna
- 7 Remote Link LED Indicator**
Indicates active connection with AM-741R Monopole Antenna
- 8 Power Input Port**
Power input port for connection of provided AC adapter

3.5 Product Specifications

Technical

Product	Active Monopole Antenna w/Remote Interface
Frequency Range	9 kHz to 30 MHz (usable up to 60 MHz)
Standard(s)	MIL-STD 461, CISPR 25, Bellcore 1089, etc.
Output Impedance	50Ω (nominal)
Active Antenna Factors	-1.4 to -0.3 (average: -0.5) dB/m (9 kHz to 30 MHz – typical)
Dynamic Range	103 dB @ 1 MHz [1 kHz bandwidth]
Saturation Level	>350 mV/m / >120 dBμV/m
VSWR (output port)	1.01 to 1.329 (average: 1.06) :1 (typical)
Return Loss (output port)	17 to 41.1 (average: 33.1) :1 (typical)

Electrical

DC Power Input	6 V_{DC}
AC to DC Power Adapter	6 V_{DC} (unregulated), 500 mA
Fuse Type	250V, 200 mA, Type T
Battery Pack	6 V_{DC} 2.0 Ah, NiMH (rechargeable)
Typical Battery Life	10-12 hours (new, fully charged battery)

RF Connectors

Antenna Port Connector	N-type (female)
Power Input Port	5.5/2.5 mm Power Jack
Fiber Optic Connector	Avago Duplex Latching POF jack

Mechanical

Dimensions (H)x(W)x(D)	2.75" x 23.8" x 23.8" (7 x 60.5 x 60.5 cm) (Not including telescoping monopole element)
Weight	9.5 lbs (4.3 kg)

Environmental

Operating Temperature	40°F to 104°F (5°C to 40°C)
-----------------------	------------------------------------

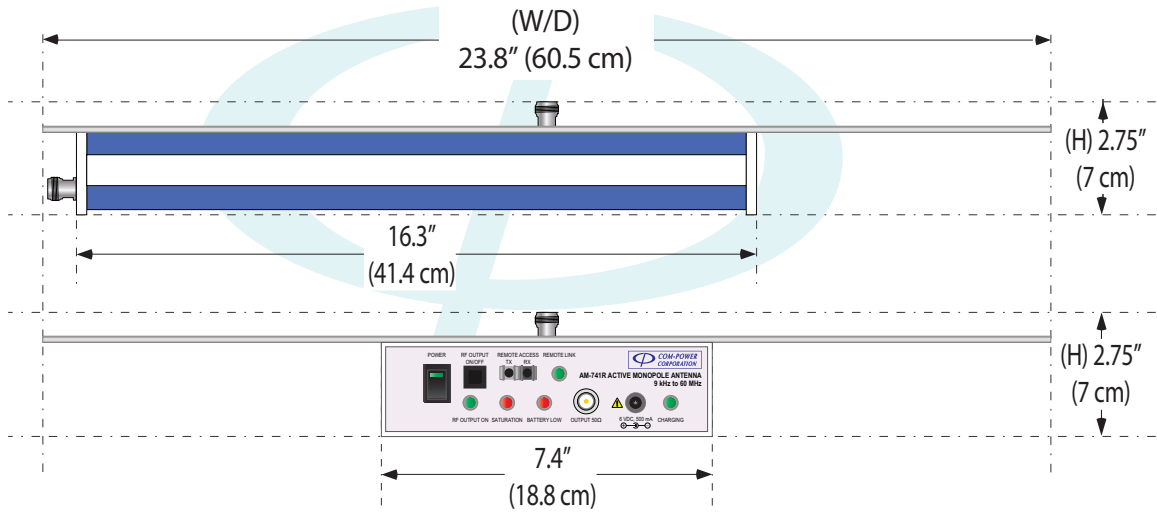

FIGURE 5 - AM-741R Active Monopole Antenna Dimensions

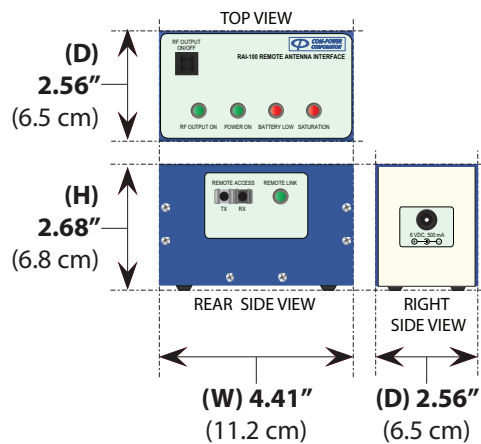

FIGURE 6 - RAI-100 Remote Antenna Interface Dimensions

4.0 Measurement Correction Factors

Anyone familiar with EMI radiated emissions measurements understands that 'uncorrected' values measured on your spectrum analyzer or EMI receiver are essentially meaningless without the appropriate 'correction' factors for the individual components of your measurement system.

A typical radiated emissions measurement system can include any combination of the following components, all of which have a quantifiable effect on the measured voltage; and therefore must be accounted for to accurately 'correct' your reading:

- **Receiving antenna(s)**
- **Preamplifier(s)**
- **Coaxial measurement cable(s)**
- **Attenuation Pad(s)**
- **Connecting Adapter(s)**
- **Low-Pass, High-Pass or Notch Filter(s)**
- **DC Block(s)**
- **Other similar measurement components**

We can separate the factors associated with the above components into three basic categories:

- 1) Antenna (or transducer) Factors,**
- 2) Gain Factors (for preamplifiers); and,**
the cables, attenuators, adapters, filters, etc., can all be lumped into one general category...
- 3) Insertion Loss Factors**

These three categories of correction factors are discussed in the following sections.

Most of today's spectrum analyzers and EMI receivers allow entry of these factors directly into the instrument. You can then group the factors into factor sets. This makes things very convenient, and allows the instrument to display/output test results as the corrected values, with no further correction necessary. These newer instruments will also allow you to enter the specification limits, so that PASS/FAIL can be determined instantaneously.

Older instruments, however, do not have this capability, so manual correction, or correction through data acquisition PC software (or other means) is needed.

Whatever the case may be, applying the *CORRECT* correction factors is obviously key to achieving accurate results. A simple typo when entering factors into your instrument or PC software will give you incorrect data *every time a test is performed* until such time that you notice the mistake, or until you recalibrate and enter the new factors. It is a good idea to double-check your entries.

4.1 Antenna Factors

Your AM-741R Active Monopole Antenna is provided with frequency-specific antenna factors, which must be added to the measured value to determine the field strength value.

Meter Reading (dBuV) + Active Ant. Factor (dB/m) = Electric Field Strength (dBuV/m)

4.2 Preamplicifier Gain Factors

Our second category of correction factors are gain factors for preamplifiers. Preamplifiers are used to increase measurement sensitivity by increasing signal to noise ratio. This is necessary when measuring low signal levels which would otherwise be buried below the inherent noise floor of the measuring instrument, typically a spectrum analyzer or EMI receiver. Ideally, input signals levels are increased proportionate to the preamp's gain, without significantly increasing the overall system noise level.

The AM-741R is an Active Monopole Antenna, and contains an internal preamplifier, so additional signal amplification should not be needed. Additionally, the preamplifier gain values are included in the antenna factor, so no additional measurement correction is necessary.

4.3 Insertion Loss Factors

As discussed previously, our third category of correction factors is insertion loss factors. These factors can include the insertion loss values of coaxial cables, band-pass or notch filters, attenuation pads, connecting adapters, etc. Basically, it includes any measurement system component (cable, adapter, combiner, divider or any other device) installed in-line with your measurement path having inherent insertion loss over the frequency range of the measurements, intentionally or unintentionally, beyond that which is considered to be negligible.

If the exact insertion loss factors (or values) are unknown for one or more component(s) of your measurement system, refer to section 4.3.1.

Insertion loss factors (or values) must be added to the measured values in order to obtain the 'corrected' values.

4.3.1 Insertion Loss Measurement

Insertion Loss values for coaxial cables and most measurement system components having a single coaxial input and output, such as attenuators, filters, dc blocks, etc., can be easily determined through a simple calibration process.

All that is typically needed is the following:

- ✓ (2) short coaxial cables and 'barrel' adapter to connect them together; and,
- either:
- ✓ a network analyzer or measuring instrument (spectrum analyzer or EMI receiver) with tracking generator;
- or:
- ✓ a measuring instrument (spectrum analyzer or EMI receiver); and,
 - ✓ a stable signal source with the appropriate frequency capabilities, such as a signal generator, function generator, or even a Com-Power Comb Generator.

4.3.1.1 Insertion Loss Measurement Procedure

- 1) REFERENCE MEASUREMENTS **(R)** - With the equipment set up as shown in Figure 3, measure and record the signal level (*in dBμV*) at several frequencies over the frequency range to be calibrated.

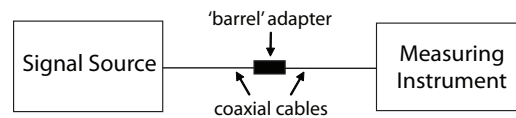

FIGURE 7 - Setup for Reference Measurements (R)

- 2) INSERTION LOSS MEASUREMENTS **(I)** - Without changing any equipment settings, and with the equipment set up as shown in Figure 4, measure and record the signal level (*in dBμV*) at the same frequencies used in Step 1.

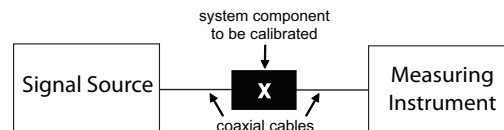

FIGURE 8 - Setup for Insertion Loss Measurements (I)

- 3) Calculate the insertion loss factor (*in dB*) for each frequency using the following formula:

$$\text{Insertion Loss Factor} = (\text{R}) \text{ minus } (\text{I})$$

5.0 Using your AM-741R Monopole Antenna

5.1 Field Strength Measurement Calculations

As discussed in section 4, the measured values must be corrected for preamplifier gain and any losses incurred along the measurement path.



FIGURE 9 - Typical measurement system for AM-741R

In the following example, we will convert an uncorrected voltage measurement into a electric field strength for comparison to the MIL-STD 461, RE101 limit of 24 dBuV/m @ 1 meter.

EXAMPLE:

We'll use the measurement system shown in Figure 9, and assume a 1-meter separation distance between the source and the antenna. We observe a signal at 30 MHz using the spectrum analyzer, and its [uncorrected] amplitude is exactly 20 dBμV.

For the system shown above, there are two (2) correction factors needed:

- 1) The AM-741R Active Antenna Factor
- 2) The Insertion Loss Factor for the cable connecting the AM-741R to the measuring instrument.

We'll assume that the insertion loss of the cable at 30 MHz is 2 dB. And, by referring to the typical antenna factor tables in Section 8, we see that the *Active Antenna Factor is -1.35 dB/m* (in practice, you will use your actual calibrated factors rather than the typical factors).

Measured amplitude @ 30 MHz =	20 dBμV
Active E-Field Antenna Factor @ 30 MHz =	-1.35 dB/m
Insertion Loss of Coaxial Cable @ 30 MHz =	2 dB
Measured Amplitude + Active Antenna Factor + Insertion Loss of Cable=	20.65 dBμV/m
MIL-STD 461 Field Strength Limit @ 1 meter =	24 dBμV/m
Limit Δ =	-3.35 dB

5.2 Antenna Positioning

The two most common arrangements for tests performed using a monopole antenna are illustrated in the following figures. Shown in Figure 10 is the arrangement described in the most recent editions of MIL-STD 461. Figure 11 shows the “classic” arrangement required by older editions of MIL-STD 461 and RTCA DO-160, as well as CISPR 25.

Refer to the standard to which you are performing tests for exact details on the measurement arrangement.

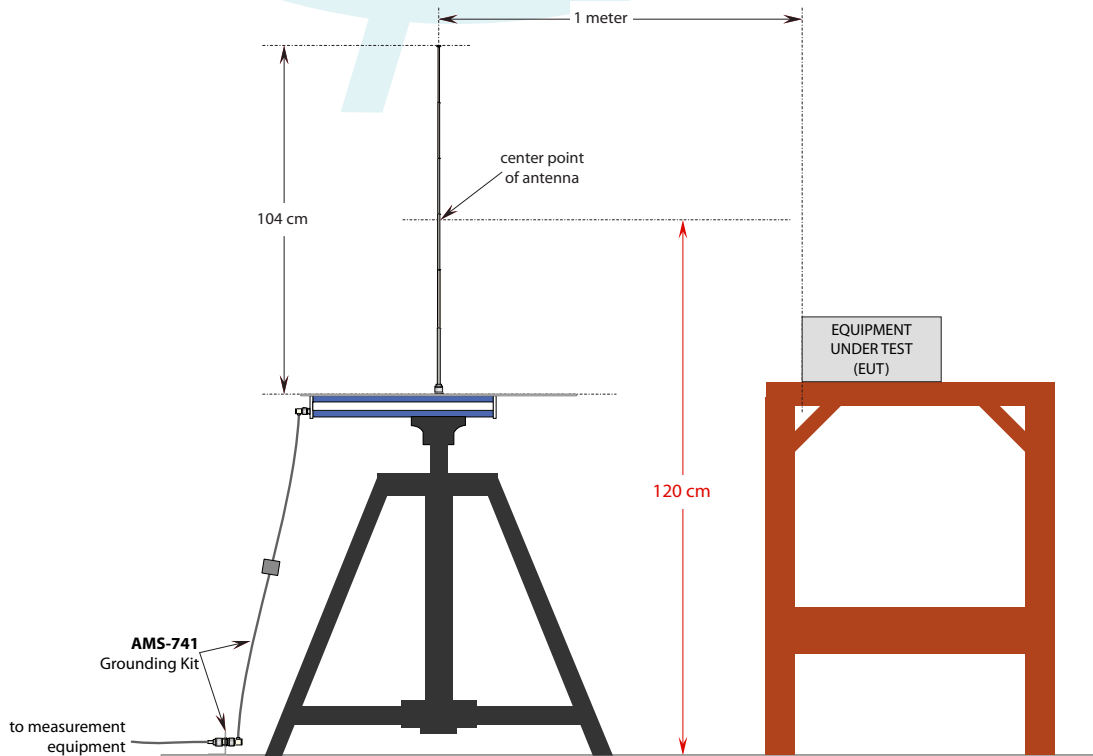

FIGURE 10 - Test Arrangement for MIL-STD 461 (recent editions)

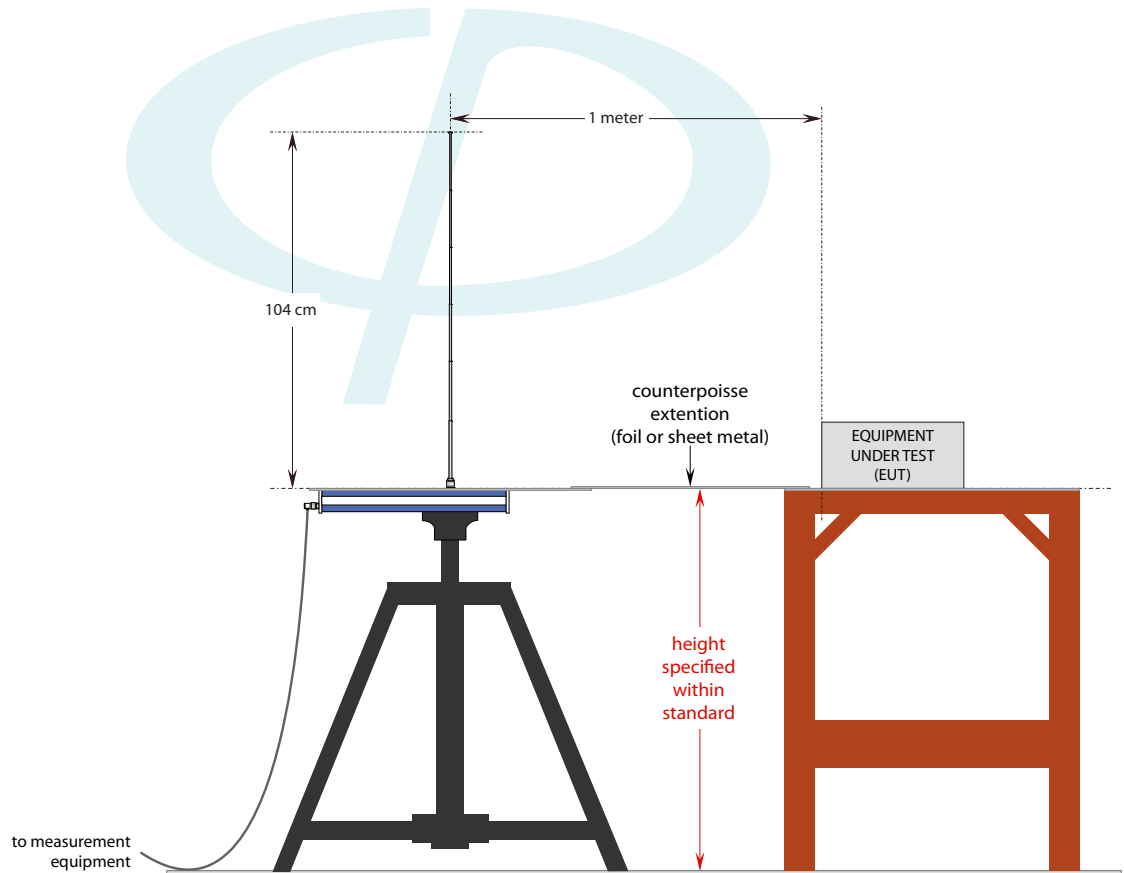
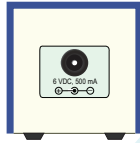

FIGURE 11 - "Classic" Test Arrangement

5.3 Using RAI-100 Remote Antenna Interface Unit

Locate the RAI-100 Remote Antenna Interface in a convenient, conspicuous location near the measurement equipment. Connect the supplied AC adapter to an appropriate power source, and connect the plug end of its cord into the RAI-100.



Secure the AM-741R Monopole Antenna into position for the measurements. Connect the AM-741R to the RAI-100 Remote Antenna Interface Unit using the supplied fiber optic cable as shown in Figure 12.

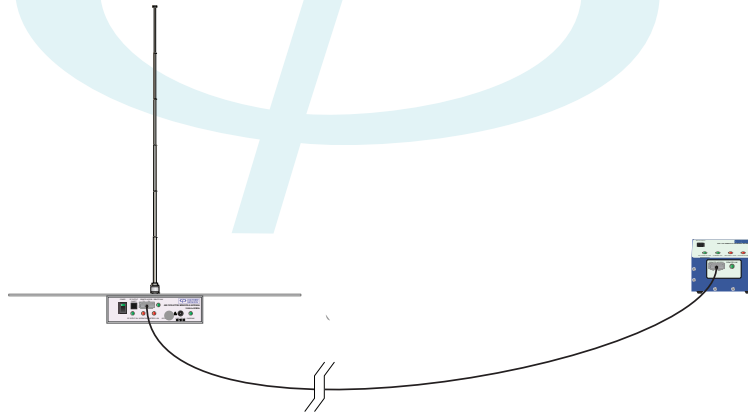
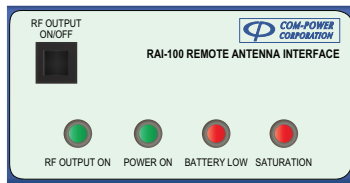

FIGURE 12 - Fiber Optic Connection from AM-741R to RAI-100

Once connected, the link will be established automatically. Once the link has been established, the green REMOTE LINK LED indicator on both the RAI-100 and AM-741R should be lit.



Now, turn on the Active Antenna's RF Output by pushing the RF OUTPUT ON/OFF pushbutton on the RAI-100 (or on the AM-741R). As long as the RF OUTPUT ON LED Indicator is lit, and the red SATURATION LED indicator is NOT lit, your Monopole antenna is ready to measure. If the SATURATION

LED indicator turns on during the test, the magnitude of the field is outside of the antenna's dynamic range, which can cause measurement inaccuracies due to unintended, non-linear operation. Avoid making measurements whenever possible when the SATURATION indicator is lit.

6.0 Calibration and Re-Calibration

Your AM-741R Active Monopole Antenna has been individually calibrated with NIST traceability, and the appropriate data and certificate has been provided.

Periodic re-calibration of the AM-741R is recommended. Calibration intervals is left to your discretion, but should be chosen based on the frequency with which it is used, and/or as allowed for by your internal quality control system (if applicable).

Com-Power offers NIST traceable calibration services. Recognized ISO 17025 accredited calibrations are also available.

6.1 Calibration of Monopole Antenna

Monopole calibration is performed using the Equivalent Capacitance Substitution Method (ECSM), which is described in ANSI C63.4, SAE ARP 958, CISPR 16-1-4 and other standards.

6.1.1 Normalization Measurements (V_{NORM})

As shown in Figure 13, the test setup is normalized by connecting both the 50Ω RF output of a network analyzer or synthesized signal generator, and the RF input of the network analyzer or a spectrum analyzer/EMI receiver, to opposite legs of a coaxial T adapter using (2) 10 dB attenuators. The third leg of the T adapter is connected to the AM-741R input port through a Com-Power AMC-10pF Calibration Capacitor. The capacitor acts as a “dummy antenna”, simulating the high impedance of the rod element. A 50 ohm terminator is connected to the output port of the AM-741R.

Measurements are made across the frequency band to be calibrated, at logarithmically spaced intervals. Results are recorded as V_{NORM} .

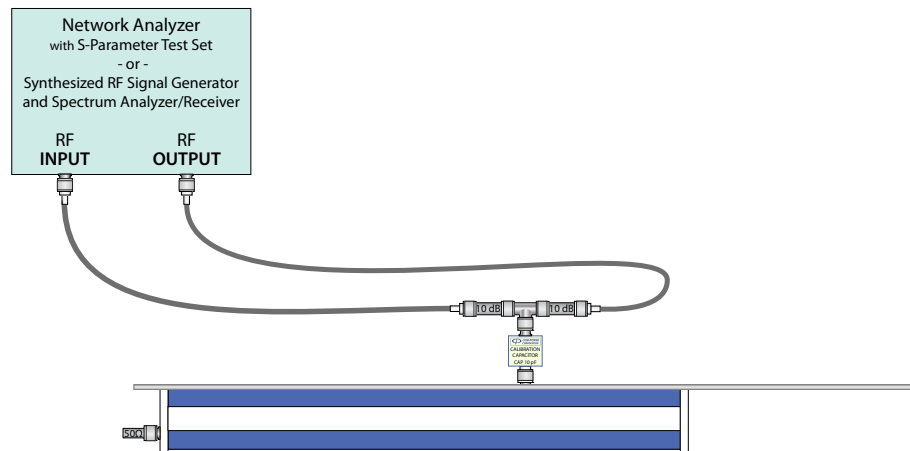

FIGURE 13 - Monopole Calibration Normalization using ECSM Method

6.1.2 Calibration Measurements (V_{CAL})

For this measurement, as shown in Figure 14, the RF input of the network analyzer or spectrum analyzer/EMI receiver, along with the 10 dB attenuator, is disconnected from the coaxial T adapter, and connected to the AM-741 output port, and the 50 ohm terminator is connected to the T adapter.

Measurements are made across the frequency band to be calibrated, at logarithmically spaced intervals. Results are recorded as V_{CAL} .

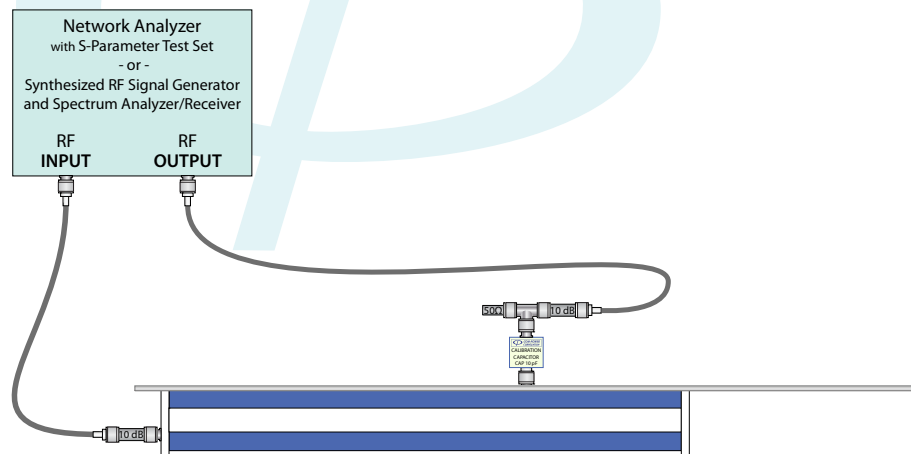

FIGURE 14 - Monopole Calibration Measurement using ECSM Method

6.1.3 Calibration Calculations

The difference between the measurements described in 6.1.1 and 6.1.2 represents the AMPLIFIER GAIN.

$$\text{AMPLIFIER GAIN} = V_{CAL} - V_{NORM}$$

The active antenna factor is then calculated as follows:

$$\text{ACTIVE ANTENNA FACTOR} = 6.02 \text{ dB} - \text{AMPLIFIER GAIN}$$

NOTE: The calibration results should be consistent ($\pm 2-3$ dB) with the typical factors given in Section 8 of this document, or with the original calibration data provided with the antenna.

7.0 Warranty

Com-Power warrants to its Customers that the products it manufactures will be free from defects in materials and workmanship for a period of three (3) years. This warranty shall not apply to:

- Transport damages during shipment from your plant.
- Damages due to poor packaging.
- Products operated outside their specifications.
- Products Improperly maintained or modified.
- Consumable items such as fuses, power cords, cables, etc.
- Normal wear
- Calibration
- Products transported outside the United States without the prior knowledge of Com-Power.

In addition, Com-Power shall not be obliged to provide service under this warranty to repair damage resulting from attempts to install, repair, service or modify the instrument by personnel other than Com-Power service representatives.

Under no circumstances does Com-Power recognize or assume liability for any loss, damage or expense arising, either directly or indirectly, from the use or handling of this product, or any inability to use this product separately or in combination with any other equipment.

When requesting warranty services, it is recommended that the original packaging material be used for shipping. Damage due to improper packaging will void warranty.

In the case of repair or complaint, Please visit our website www.com-power.com and fill out the RMA form (<http://com-power.com/repairservicereq.asp>). Our technical assistance personnel will contact you with RMA number. The RMA number should be displayed in a prominent location on the packaging and on the product, along with a description of the problem, and your contact information.

Typical Active Antenna Factors



Active Monopole Antenna

Equipment:		Com-Power Active Monopole Antenna	
Model:		AM-741	
Serial Number:			
Calibration Date:			
Frequency (MHz)	Active Antenna Factor (dB/m)	Frequency (MHz)	Active Antenna Factor (dB/m)
0.009	-0.48	10.00	-0.76
0.01	-0.49	12.00	-0.79
0.02	-0.52	14.00	-0.83
0.03	-0.54	16.00	-0.88
0.04	-0.54	18.00	-0.92
0.05	-0.56	20.00	-0.95
0.06	-0.56	22.00	-0.99
0.07	-0.56	24.00	-1.08
0.08	-0.57	26.00	-1.15
0.09	-0.58	28.00	-1.28
0.1	-0.59	30.00	-1.35
0.2	-0.61	32.00	-1.43
0.4	-0.63	34.00	-1.52
0.6	-0.63	36.00	-1.63
0.8	-0.63	38.00	-1.72
1	-0.64	40.00	-1.79
2	-0.66	45.00	-2.01
4	-0.68	50.00	-2.18
6	-0.70	55.00	-2.31
8	-0.71	60.00	-2.35
<p>Calibration performed according to Equivalent Capacitance Substitution Method (ECSM) method described in SAE ARP958 Revision D (Section 5) and ANSI C63.5: 2006</p> <p>Active Antenna Factor = 6.02 - Amplifier Gain</p> <p>Active Antenna Factor to be added to receiver reading:</p> <p>Meter Reading (dBuV) + Active Antenna Factor (dB/m) = Corrected Reading (dBuV/m)</p>			